

Journal

Website: <https://theamericanjournals.com/index.php/tajet>

Copyright: Original content from this work may be used under the terms of the creative commons attributes 4.0 licence.

Research Article

MAGNETIC FIELD IN THE AIR GAP OF AN INDUCTION MOTOR GENERAL INSPECTION INFORMATION APPLICATIONS

Submission Date: November 20, 2023, Accepted Date: November 25, 2023,

Published Date: November 30, 2023

Crossrefdoi: <https://doi.org/10.37547/tajet/Volume05Issue11-20>

Pirmatov N.B.

Tashkent State Technical University Professo Pirmatov N.B Andijan Machena Bulding Instute Doktorant (Phd)Nizamov J.A Tashkent State Technical University Assistant Ergashev Sh.O, Uzbekistan

Nizamov J.A.

Tashkent State Technical University Professo Pirmatov N.B Andijan Machena Bulding Instute Doktorant (Phd)Nizamov J.A Tashkent State Technical University Assistant Ergashev Sh.O, Uzbekistan

Ergashev Sh.O.

Tashkent State Technical University Professo Pirmatov N.B Andijan Machena Bulding Instute Doktorant (Phd)Nizamov J.A Tashkent State Technical University Assistant Ergashev Sh.O, Uzbekistan

ABSTRACT

This article considers a device for measuring the magnetic stray field of the frontal part of the squirrel-cage rotor winding of an asynchronous motor for general industrial use.

In this device for measuring the magnetic field of leakage of the frontal part of the squirrel-cage rotor winding in the bearing shield against the frontal part of the squirrel-cage rotor winding in the form of an arc, a sensor is installed with a length equal to the pole division and a radius equal to the radius of the location of the heads of the frontal parts of the squirrel-cage rotor winding of an asynchronous motor of general industrial use.

KEYWORDS

Asynchronous motor, magnetic field scattering of the frontal part, stator, rotor, pole division, bearing shield.

INTRODUCTION

The magnetic field in the stator coil end area of electrical machines has a complex distribution. This is due to many factors, the main ones being: the type of winding used in the electric machine, the configuration

of the overhead parts and their spatial distribution, the angle of the overhead parts towards the machine axis, the presence of surfaces with different magnetic and electrical permeability surrounding the overhead part.

Knowledge of the field pattern is necessary to determine the electrodynamic forces acting on the stator windings and surrounding structures to determine the inductive resistance of the overhangs, to determine the losses in the stator core end sections and in the massive structural elements in the machine end section.

METHODOLOGY

There is a known method for modelling the magnetic field scattering of the stator and rotor windings of a synchronous machine [1].

The simulation of the magnetic field of the overhead scattering of synchronous machine windings in operational modes of operation is carried out by dividing the process into two stages. In the first stage, the magnetic field of a single winding of the stator section and the rotor coil with current $I = 1$ A is simulated. The stator section is assumed to be symmetrical in the calculation. Then using the known distribution of the magnetic field of one coil, the location of the sections in the stator core, the magnetic field from the stator phase head is simulated by superposition method.

In the second step, the magnetic field from the front end of the stator of a synchronous machine is determined from the known dependencies of induction $B_{l.v}(X)$ and $B_{z.l.v}(X)$.

The disadvantage of this method is its complexity and inaccuracy, as the results of the magnetic field induction calculation using this method do not satisfy the boundary conditions due to the asymmetric currents.

A device is known for experimental investigation of the electromagnetic field in the stator winding frontal area in the presence of conductive screens [2].

The research was carried out on a static stator end model of a two-pole shock generator with a single-phase concentric winding, the frontal parts of which are 900. The simulation winding consisted of two coil groups connected in series, with six coils in each group. The coils were wound with 10x2.5 mm rectangular copper wire and had one turn each. Power was supplied by alternating voltage with a frequency of 50 Hz. A special probe with three Hall sensors was made for convenient measurement of the magnetic scattering field and subsequent processing of the experimental results.

The disadvantage of this method is the complexity of the simulation winding design and the inaccuracy of measuring the magnetic stray field of the machine's stator winding front end.

A device is also known for measuring and recording the coast angle of an explicitly pole synchronous machine [3].

An arc-shaped probe with a length equal to the pole division and a radius equal to the radius of the rotor winding heads of the synchronous machine is mounted in the bearing shield against the rotor winding head.

As the excited rotor of a synchronous machine running in parallel with the mains rotates, the magnetic stray field of the rotor winding induces an EMF in the conductor.

The disadvantage of this device is the limited use of the sensor for other electrical equipment.

This article is based on the task of extending the range of application of the sensor for measuring the magnetic stray field of the squirrel cage rotor winding of an asynchronous motor for general industrial applications.

The task is solved by the fact that in this device for measuring the magnetic field of scattering of the frontal part of the short-circuited rotor winding in the bearing shield against the frontal part of the short-circuited rotor winding in the form of an arc is installed sensor with length equal to the pole division and radius equal to the radius of the heads of the short circuit rotor winding of an induction motor of general industrial application.

The proposed device differs from the known ones in that in order to measure the magnetic field of scattering of the short-circuited rotor winding, a sensor with length equal to the pole division and radius equal to the radius of the heads of the short-circuited rotor winding of an induction motor of general industrial application is installed in the bearing plate against the frontal part of the short-circuited rotor winding in the form of an arc.

Fig.1 shows mounting and location of the sensor in two projections, and Fig.2 shows variation of magnetic field of scattering of short-circuited rotor winding of an asynchronous motor of general industrial application.

According to Fig. 1 the proposed device contains a frontal part of the short-circuited rotor winding 1, against the frontal part of the short-circuited rotor winding 1 there is a sensor (measuring conductor) 2 in the form of an arc with the length equal to one pole division τ and the radius equal to the radius of the frontal part of the short-circuited rotor winding 1.

To measure the magnetic stray field of the short-circuited rotor winding 1, the input ends of sensor (measuring lead) 2 are connected to the vibrator of the oscilloscope.

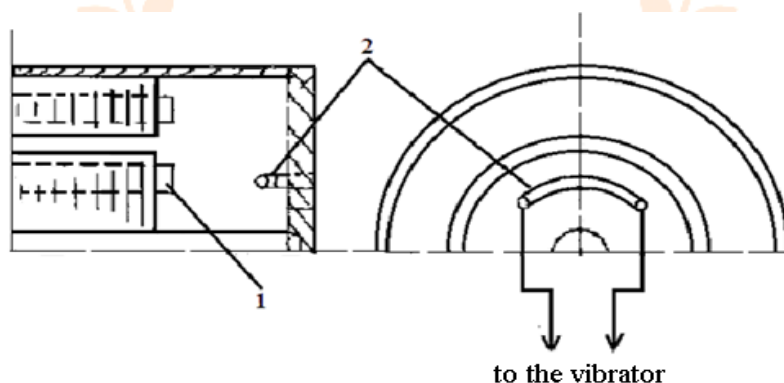

Fig.1. Sensor mountings and locations in two projections

EXPERIMENTAL RESULTS

Figure 2 shows an oscillogram of the EMF of the magnetic stray field 3 in the winding of short-circuit rotor winding 1 for a general purpose induction motor.

The proposed device works as follows. When a three-phase supply is connected to the stator winding terminals, a magnetic field of scattering of the frontal part of the short-circuited rotor winding 1 arises in the frontal part of the short-circuited rotor winding 1. In this case, the magnetic field of scattering of the frontal

part of the short-circuited rotor winding 1 induces an EMF in the measuring conductor 2. If it is necessary to oscillograph the magnetic field of scattering of the

frontal part of the short-circuited rotor winding 1, the lead ends of the measuring conductor 2 are connected to the oscilloscope.

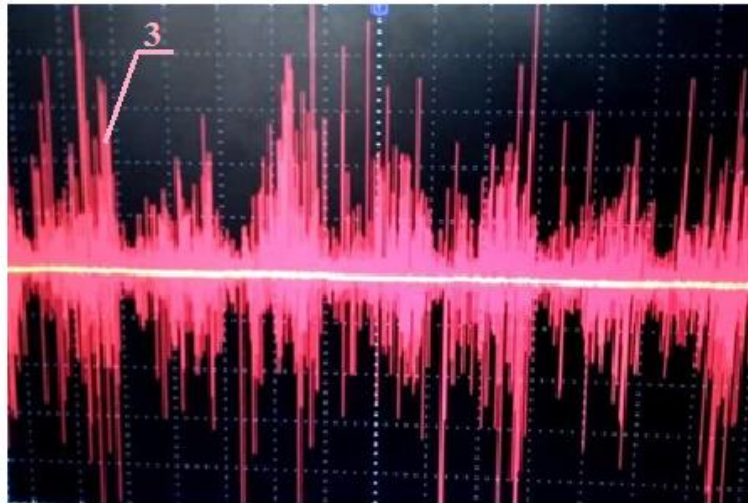

Figure 2. Oscillogram of EMF of the magnetic field scattering at the end of the short-circuit rotor winding of an induction motor

CONCLUSION AND FUTURE WORK

Thus, the use of the device proposed by the authors, along with expanding its field of application, will lead to improved accuracy of measuring the magnetic field of dispersion of the frontal part of the short-circuited rotor winding of asynchronous motor of general industrial applications

REFERENCES

1. Novozhilov A.N. Calculation of point measuring transducers for synchronous motor protection//Electrotechnics. - 1995. -Nº10. C. 45-48.
2. Oganyan L.O. Experimental study of electromagnetic field in stator winding frontal area in presence of conductive screens. Izvestiya Tomskogo instituta Oktyabrskaya redvolionna i ordrovanii trudovogo red bannera politekhnika imeni S.M.Kirov [Proceedings of Tomsk Polytechnic Institute named after S.M.Kirov]. 1973.vol.265. -C. 48-54
3. Akhmatov M.G., Pirmatov N.B., Salimov D.S. et al. Device for measuring and registering the angle of run-out of an apparent-pole synchronous machine. Preliminary patent RUz. Published 01.03.1995 № 368.
4. Pirmatov, N, Muminov, M., Akberdiev, M., Abdullayev, J. Use of Hybrid Renewable Energy Systems to Excite Autonomous Synchronous Machines AIP Conference Proceedings, 2022, 2432, 020020.
5. Akhmatov, M.G., Pirmatov, N.B.. Calculation of winding factors and MMFs of rotor windings of synchronous machines with longitudinal-transversal excitation. Elektrichestvo, 2003, (3), pp. 68-70.
6. R Karimov, M Bobojanov, Analysis of voltage stabilizers and non-contact relays in power supply

- systems, (E3S Web of Conferences 216, 01162, 2020).
<https://doi.org/10.1051/e3sconf/202021601162>.
7. R Karimov, Study of the state of the issue of increasing the quality of electric energy in the power supply systems, (E3S Web of Conferences 216, 01163, 2020).
<https://doi.org/10.1051/e3sconf/202021601163>.
 8. R Karimov, M Bobojanov and others, Non-contact controlled voltage stabilizer for power supply of household consumers, (IOP Conf. Series: Materials Science and Eng.: 883(1), 012120, 2020).
doi:10.1088/1757-899X/883/1/012120.
 9. Khushnud Sapaev, Shukhrat Umarov, Islombek Abdullabekov. Critical frequency of autonomous current inverter when operating on active-inductive load E3S Web of Conferences 216, 01153 (2020) The Authors, published by EDP Sciences. This is an open access article distributed under the terms of the Creative Commons Attribution License 4.0 (<http://creativecommons.org/licenses/by/4.0/>).
 10. Nizamov J.A., Daliyev I.I. Umummaqsadli asinxron motor stator chulg'ami tirsak qismining sochilma magnit maydonini o'lchovchi qurilma// Axborot oqimlari va intellektual tizimlarning ijtimoiy, iqtisodiy va texniktexnologik tarmoqlardagi o'rni 2023 №118 992-996 b
 11. Nizamov J.A., Daliyev I.I. Qisqa tutashgan rotorli asinxron motor rotor chulg'amining tirsak qismidagi sochilma magnit maydonini o'lchovchi qurilma // Axborot oqimlari va intellektual tizimlarning ijtimoiy, iqtisodiy va texniktexnologik tarmoqlardagi o'rni 2023 №118 1428-1431 b
 12. Pirmatov N.B., Nizamov J.A., Ergashev Sh.O., Berdiyrov U.N. Device for Measuring Scattered Magnetic Field of Stator Winding Head Asynchronous Motor for General Industrial Application// International Journal of Advanced Research in Science, Engineering and Technology Vol. 10, Issue 4, April 2023 20564 – 20567 pp
 13. Pirmatov N.B., Nizamov J.A., Ergashev Sh.O., Berdiyrov U.N. Device for Measuring the Magnetic Field of Scattering of the Winding of a Short-Circuited Rotor of an Asynchronous Motor for General Industrial Applications// International Journal of Advanced Research in Science, Engineering and Technology Vol. 10, Issue 4, April 2023 20517- 20519 pp
 14. Pirmatov N.B., Nizamov J.A., Ergashev Sh.O., Berdiyrov U.N. Umummaqsadli asinxron mashina havo oralig'idagi magnit maydonning yig'indi elektr yurituvchi kuchi va asosiy elektr yurituvchi kuchi orasidagi siljish burchagini o'lchash qurilmasi// O'zbekiston Respublikasi Adliya vazirligi huzuridagi intellektual mulk agentligi № FAP 02215
 15. Pirmatov N.B., Nizamov J.A., Ergashev Sh.O., Berdiyrov U.N. Asinxron motorlarning tashqi sochilma magnit maydonini olchovchi qurilma// O'zbekiston Respublikasi Adliya vazirligi huzuridagi intellektual mulk agentligi № FAP 77115
 16. Pirmatov N.B., Nizamov J.A., Ergashev Sh.O., Berdiyrov U.N., Boixanov Z. U. Asinxron motorlarining texnik holatlarining aniqlash vositalari va usullarining diagnostikasi// O'zbekiston Respublikasi Adliya vazirligi huzuridagi Intellektual mulk agentligi № DGU 16005